

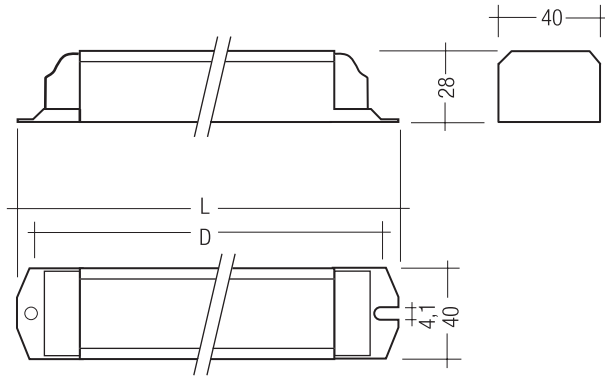

PC T8 PRO, 30 – 70 W PC PRO T8

Product description

- CELMA Energy Efficiency Index A2
- Nominal life time up to 50,000 h (at ta 50 °C with a failure rate max. 0.2 % per 1,000 h)
- Large temperature range (for values see table)
- Intelligent Voltage Guard (overvoltage indication and undervoltage shutdown)
- Constant luminous flux irrespective of fluctuations in mains voltage
- For luminaires of protection class I and protection class II
- Automatic start after replacement of defective lamps
- Safety shutdown of defective lamps and at end of lamp life
- Insulation Displacement Connection (IDC) terminal for rapid automatic or manual wiring
- For emergency lighting systems as per EN 50172
- For luminaires with F or M and MM as per EN 60598, VDE 0710 and VDE 0711
- Temperature protection as per EN 61347-2-3 C5e



Technical data

AC voltage range	198 – 264 V
DC voltage range	176 – 280 V (Lamp start \geq 198 V DC)
Overvoltage protection	320 V AC, 1 h
Defined warm start	\leq 1.5 s
Operating frequency	\geq 40 kHz
Type of protection	IP20



Standards, page 3

Wiring diagrams and installation examples, page 5

Ordering data

Type	Article number	Packaging carton	Packaging pallet	Weight
For luminaires with 1 lamp				
PC 1/30 T8 PRO	22176077	10 pc./pcs.	630 pc./pcs.	0.221 kg
PC 1/70 T8 PRO	22176171	10 pc./pcs.	630 pc./pcs.	0.202 kg
For luminaires with 2 lamps				
PC 2/30 T8 PRO	22176078	10 pc./pcs.	630 pc./pcs.	0.212 kg
PC 2/70 T8 PRO	22176232	10 pc./pcs.	420 pc./pcs.	0.318 kg
For luminaires with 3 lamps				
PC 3/36 T8 PRO	22176231	10 pc./pcs.	420 pc./pcs.	0.304 kg

Specific technical data

Lamp wattage	Lamp type	Type	Article number	Dimensions L x W x H	Hole spacing D	Lamp power	Circuit power	EEI	Current at 50 Hz		λ at 50 Hz		tc point max.	Ambient temperature ta
									220 V	240 V	220 V	240 V		
For luminaires with 1 lamp														
1 x 30 W	T8	PC 1/30 T8 PRO	22176077	234 x 40 x 28 mm	220 mm	24 W	28.0 W	A2	0.13 A	0.12 A	0.97	0.96	75 °C	-25 ... 60 °C
1 x 70 W	T8	PC 1/70 T8 PRO	22176171	234 x 40 x 28 mm	220 mm	60 W	65.6 W	A2	0.30 A	0.28 A	0.99	0.98	75 °C	-25 ... 55 °C
For luminaires with 2 lamps														
2 x 30 W	T8	PC 2/30 T8 PRO	22176078	234 x 40 x 28 mm	220 mm	50 W	56.0 W	A2	0.26 A	0.24 A	0.97	0.96	75 °C	-25 ... 60 °C
2 x 70 W	T8	PC 2/70 T8 PRO	22176232	360 x 40 x 28 mm	350 mm	120 W	136.8 W	A2	0.62 A	0.57 A	0.99	0.99	70 °C	-25 ... 50 °C
For luminaires with 3 lamps														
3 x 36 W	T8	PC 3/36 T8 PRO	22176231	360 x 40 x 28 mm	350 mm	96 W	106.5 W	A2	0.51 A	0.47 A	0.99	0.98	70 °C	-25 ... 50 °C

Standards

EN 55015
EN 61347-2-4
EN 61347-2-3
EN 60929
EN 61000-3-2
EN 61547
in accordance with EN 50172
IEC 68-2-64 Fh
IEC 68-2-29 Eb
IEC 68-2-30

Lamp starting characteristics

Warm start
Starting time 1.5 sec. with AC and DC operation
Cathode heating will be reduced after preheat time

AC operation

Mains voltage:
220–240 V 50/60 Hz
198–264 V 50/60 Hz including safety tolerance ($\pm 10\%$)
202–254 V 50/60 Hz including performance tolerance ($+6\% / -8\%$)

DC operation

220–240 V 0 Hz
198–280 V 0 Hz certain lamp start
176–280 V 0 Hz operating range
Light output level in DC operation: 100 %

Emergency lighting

Use in emergency lighting installations according to EN 50172 or for emergency luminaires according to EN 61347-2-3 appendix J.

Instant start after mains interruption < 0.5 s

Intelligent Voltage Guard

Intelligent Voltage Guard is the name of the new electronic monitor from Tridonic. This innovative feature of the PC PRO family of control gear from Tridonic immediately shows if the mains voltage rises above or falls below certain thresholds. Measures can then be taken quickly to prevent damage to the control gear.

- If the mains voltage rises above approx. 306 V (voltage depends on the ballast type), the lamp starts flashing on and off.
- This signal "demands" disconnection of the power supply to the lighting system.
- If the mains voltage falls below 150 V the control gear automatically disconnects the lamp circuit to protect the control gear from being irreparably damaged.

Smart Heating

Innovative heating circuit. Reduced filament heating after lamp has struck.

Mains currents in DC operation

Type	Lamp type	Wattage	Mains current at	
			$U_n = 220 V_{DC}$	$U_n = 240 V_{DC}$
PC 1/30 T8 PRO	T8	1x30 W	0.16 A	0.15 A
PC 2/30 T8 PRO	T8	2x30 W	0.27 A	0.25 A
PC 3/36 T8 PRO	T8	3x36 W	0.51 A	0.46 A
PC 1/70 T8 PRO	T8	1x70 W	0.30 A	0.28 A
PC 2/70 T8 PRO	T8	2x70 W	0.61 A	0.57 A

Harmonic distortion in the mains supply

Type	Lamp type	Wattage	THD
			at 230V/50Hz
PC 1/30 T8 PRO	T8	1x30 W	$< 10\%$
PC 2/30 T8 PRO	T8	2x30 W	$< 10\%$
PC 3/36 T8 PRO	T8	3x36 W	$< 10\%$
PC 1/70 T8 PRO	T8	1x70 W	$< 10\%$
PC 2/70 T8 PRO	T8	2x70 W	$< 10\%$

Working voltage

Type	Lamp type	Wattage	U_{out}
PC 1/30 T8 PRO	T8	1x30 W	250 V
PC 2/30 T8 PRO	T8	2x30 W	250 V
PC 3/36 T8 PRO	T8	3x36 W	250 V
PC 1/70 T8 PRO	T8	1x70 W	250 V
PC 2/70 T8 PRO	T8	2x70 W	250 V

Ballast lumen factor (EN 60929 8.1)

Type	Lamp type	Wattage	AC/DC-BLF
			at $U = 198-254 V, 25^\circ C$
PC 1/30 T8 PRO	T8	1x30 W	1.00
PC 2/30 T8 PRO	T8	2x30 W	1.00
PC 3/36 T8 PRO	T8	3x36 W	1.05
PC 1/70 T8 PRO	T8	1x70 W	1.00
PC 2/70 T8 PRO	T8	2x70 W	1.00

PC PRO with xitec processor

Is the very latest in lighting management design technology. The lamp friendly warm start is delivering maximum T8 lamp life and enables high switching frequency applications. Smallest power loss and new freedom in the lamp design thanks to convincing thermal management.

Energy class CELMA EEI = A2¹⁾

PC T8 PRO ignition technology (smart heating) optimises lamp start and ensures no energy is wasted. After the lamp has struck the filament heating is reduced automatically to a defined minimum value. This reduction in filament heating, saves energy, yet maintains the proper operating conditions for the lamp. The lamp is always operated within specification.

¹⁾ according to the EU directives on ecodesign requirements (EC) No. 245/2009 and (EC) No. 347/2010

PC 1/70 T8 PRO

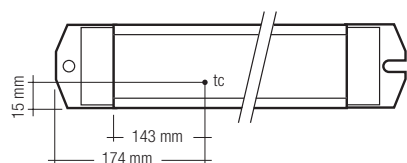

PC 1/30 T8 PRO, PC 2/30 T8 PRO

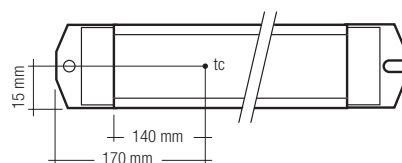

PC 3/36 T8 PRO, PC 2/70 T8 PRO

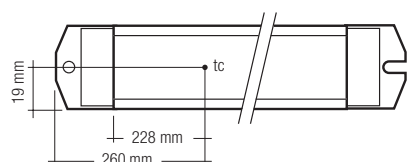

Ambient Temperature

-25 °C to +50 °C resp. 55 °C resp. 60 °C

The nominal ta and tc point are related to the ballast life duration.

The relation of tc to ta temperature depends also on the luminaire design. If the measured tc temperature is approx. 5 K below tc max., ta temperature should be checked and eventually critical components (e.g. ELCAP) measured. Detailed information on request.

PC T8 PRO is designed for an average service life of 50,000 hours under reference conditions and with a failure probability of less than 10 %. This corresponds to an average failure rate of 0.2 % for every 1,000 hours of operation.

Humidity: 5 % up to max. 85 %, not condensed (max. 56 days/year at 85 %)

Storage temperature: -40 °C up to max. +80 °C

The devices have to be within the specified temperature range (ta) before they can be operated.

Expected lifetime

Type	Lamp type	Lamp wattage	ta	40 °C	50 °C	55 °C	60 °C
PC 1x30 T8 PRO	T8	1x30 W	tc	55 °C	65 °C	70 °C	75 °C
			Lifetime	> 100,000 h	100,000 h	70,000 h	50,000 h
PC 1x70 T8 PRO	T8	1x70 W	tc	60 °C	70 °C	75 °C	x
			Lifetime	> 100,000 h	70,000 h	50,000 h	x
PC 2x30 T8 PRO	T8	2x30 W	tc	55 °C	65 °C	70 °C	75 °C
			Lifetime	100,000 h	100,000 h	70,000 h	50,000 h
PC 2x70 T8 PRO	T8	2x70 W	tc	60 °C	70 °C	x	x
			Lifetime	100,000 h	50,000 h	x	x
PC 3x36 T8 PRO	T8	3x36 W	tc	60 °C	70 °C	x	x
			Lifetime	100,000 h	50,000 h	x	x

x = not permitted

Maximum loading of automatic circuit breakers

Automatic circuit	C10	C13	C16	C20	B10	B13	B16	B20
Installation Ø	1.5 mm ²	1.5 mm ²	1.5 mm ²	2.5 mm ²	1.5 mm ²	1.5 mm ²	1.5 mm ²	2.5 mm ²
PC 1/30 T8 PRO	40	52	60	72	19	26	30	36
PC 2/30 T8 PRO	22	30	38	42	11	15	19	21
PC 3/36 T8 PRO	18	24	32	40	9	12	16	20
PC 1/70 T8 PRO	20	26	34	42	10	13	17	21
PC 2/70 T8 PRO	10	14	18	20	5	7	9	10

Wiring advice

The lead length is dependant on the capacitance of the cable.
For safety reasons, the PC T8 PRO must only be earthed in the case of a safety class 1 luminaire.
Earthing is not required for the device to operate. Connection to earth reduces radio interference.

Ballast Type	Terminal	Maximum capacitance allowed			
		Cold	Hot	Kalt	Heiß
PC 1xx T8 PRO		11, 12	9, 10	200 pF	100 pF
PC 2xx T8 PRO		11, 12, 13, 14	9, 10	200 pF	100 pF
PC 3xx T8 PRO		11, 12, 13, 14, 15, 16	9, 10	200 pF	100 pF

To avoid the damage of the control gear, the wiring must be protected against short circuits to earth (sharp edged metal parts, metal cable clips, louver, etc.)

Installation instructions

IDC interface

- solid wire with a cross section of 0.5 mm² according to the specification from WAGO

Horizontal interface

- solid wire with a cross section of 0.5–1.5 mm² according to the specification from WAGO
- strip 7.5–8.5 mm of insulation from the cables to ensure perfect operation of the push terminals

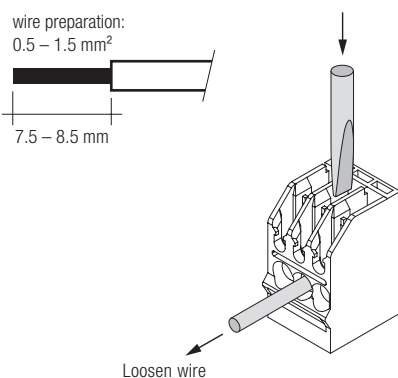

Defective lamp

If a lamp is defective, the ballast switches off and goes into standby. There is an automatic restart once the lamp has been changed.

Isolation and electric strength testing of luminaires

Electronic devices can be damaged by high voltage. This has to be considered during the routine testing of the luminaires in production.

According to IEC 60598-1 Annex Q (informative only!) or ENEC 303-Annex A, each luminaire should be submitted to an isolation test with 500 V_{DC} for 1 second. This test voltage should be connected between the interconnected phase and neutral terminals and the earth terminal.
The isolation resistance must be at least 2 MΩ.

As an alternative, IEC 60598-1 Annex Q describes a test of the electrical strength with 1500 V_{AC} (or 1.414 x 1500 V_{DC}). To avoid damage to the electronic devices this test must not be conducted.

T8 lamp information

	wattage	length
	30 W	900 mm
	36 W	1200 mm
	70 W	1800 mm

With standard solid wire 0.5/0.75 mm² the capacitance of the lead is approx. 80 pF/m. This value is influenced by the way the wiring is made. In borderline cases the capacitance must be measured inside the luminaire.
Keep lamp wires short. Lamp connection with twin ballast should be made with symmetrical wiring. Hot leads and cold leads should be separated as much as possible.

RFI

Tridonic ballasts are RFI protected in accordance with EN 55015:2006 and A1:2007. To operate the luminaire correctly and and to minimise RFI we recommend the following instructions:

- Connection to the lamps of the "hot leads" must be kept as short as possible (marked with *)
- Mains leads should be kept apart from lamp leads (ideally 5–10 cm distance)
- Do not run mains leads adjacent to the electronic ballast
- Twist the lamp leads
- Keep the distance of lamp leads from the metal work as large as possible
- Connect functional earth, either over the terminal or over the mounting screw of the ballast
- Mains wiring to be twisted when through wiring
- Keep the mains leads inside the luminaire as short as possible

Additional information

Additional technical information at www.tridonic.com → Technical Data

Guarantee conditions at www.tridonic.com → Services

No warranty if device was opened.

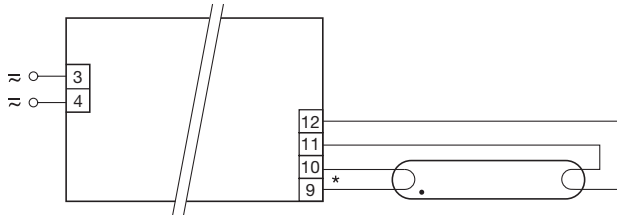

* leads 9, 10 max. 1.0 m (< 100 pF)
leads 11, 12 max. 2.0 m (< 200 pF)
For luminaires of protection class I: Earthing via ECG casing (according to IEC 60598)
For luminaires of protection class II: No earthing required

PC 1x30-70 W T8 PRO

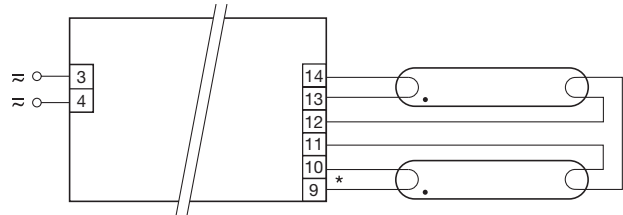

* leads 9, 10 max. 1.0 m (< 100 pF)
leads 11, 12, 13, 14 max. 2.0 m (< 200 pF)
For luminaires of protection class I: Earthing via ECG casing (according to IEC 60598)
For luminaires of protection class II: No earthing required

PC 2x30-70 W T8 PRO

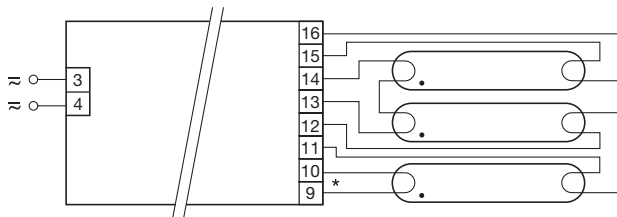

* leads 9, 10 max. 1.0 m (< 100 pF)
leads 11, 12, 13, 14, 15, 16 max. 2.0 m (< 200 pF)
For luminaires of protection class I: Earthing via ECG casing (according to IEC 60598)
For luminaires of protection class II: No earthing required

PC 3x36 W T8 PRO