

BCS
TC Twingle
Series

Non-dimmable electronic control gear units for compact fluorescent lamps in Twingle technology

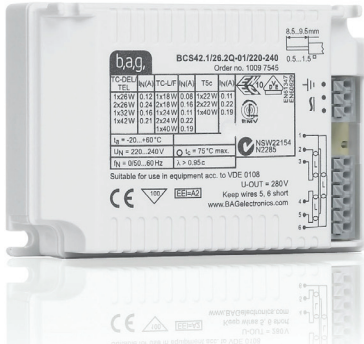

Performance characteristics

- Twingle-Technology: Optional operation of 1 or 2 lamps
- Multipower: operation of different lamps and wattages
- Maximum lamp life thanks to electrode preserving warmstart, even at increased switching frequency; starting time < 1.5 s
- Automatic restart after lamp replacement
- Safety switch-off in case of abnormal lamp operation, e.g. defective electrode and end of lamp life; tested acc. to EN 61347-2-3
 - Overvoltage protection up to 350 VAC/2 h
- Certified as thermally protected ballasts, e.g. for application in ∇ -luminaires
- Suitable for DC operation and use in emergency applications: Meets the requirements for emergency lighting 61347-2-3 / J
- Energy efficiency index EEL=A2
- Nominal service life: 50,000 h with failure rate \leq 10% and operation at $t_c=t_{c,max}$
- Conformance with international regulations regarding safety and operation, electromagnetic compatibility and immunity to interference

ECG model

Version	Order no.	Lamp	
BCS17.1-2Q-01/220-240	10097542	1/2 x TC-HE	14 W
		1/2 x TC-HE	17 W
BCS18.1-2Q-01/220-240	10097544	1/2 x TC-DEL/-TEL	18 W
BCS21.1-2Q-01/220-240	10097543	1/2 x T5	14 W
		1 x T5	21 W
		1/2 x TC-DD	10 W
		1/2 x TC-DD	16 W
		1/2 x TC-DEL	10 W
		1/2 x TC-DEL/-TEL	13 W
		1/2 x TC-SE	9 W
BCS42.1/26.2Q-01/220-240	10097545	1 x T12	40 W
		1/2 x T5C	22 W
		1 x T5C	40
		1/2 x T5	24 W
		1 x T5	39 W
		1/2 x T8	15 W
		1/2 x T8	18 W
		1 x T8	36 W
		1 x T8	38 W
		1/2 x TC-L/-F	18 W
		1/2 x TC-L/-F	24 W
		1 x TC-L	40 W
BCS70.1/42.2Q-01/220-240	10097546	1/2 x TC-DEL/-TEL	26 W
		1/2 x TC-TEL	32 W
		1/2 x TC-TEL	42 W
		1 x TC-TEL	57 W
		1 x TC-TEL	70 W
		2 x T5C	22 W
		2 x T5C	40&22 W

Markings



Technical data

Mains voltage supply	
Rated voltage range	220 V – 240 V
Max. admissible voltage range (continuous)	198 V – 264 V
Frequency	0/ 50 Hz ... 60 Hz
Battery operation	
Voltage range for continuous operation	198 VDC – 278 VDC
Lowest limiting value for temporary operation	176 VDC - 198 VDC ¹⁾
Behaviour at mains overvoltage	
Switch-off of the lamp(s) at	approx. 320 VAC ²⁾
Overvoltage protection	350 VAC / 2 h
Leakage current	< 0.5 mA / ECG
Ignition time of the lamp	< 1.5 s
Behaviour in case of defective lamp	Switch-off of the lamp(s)
Automatic restart after lamp replacement	yes
Max. temperature at housing surface	+ 110 °C (acc. EN 61 347-2-3/C)
Nominal service life: (failure rate ≤ 10%)	100.000 h at $t_c = t_{c, max} - 10K$ 50.000 h at $t_c = t_{c, max}$
Lamp and mains terminals for solid or stranded wire	
Type	45°-connector with push button
Wire cross section	0.5 mm ² – 1.5 mm ²
Wire stripping length	7.5 mm ² – 8.5 mm ²
Lamp wire lengths	see "wiring diagrams"

¹⁾ Reliable lamp ignition only for ≥ 198 VDC, for max. 0,5 h

²⁾ Automatic lamp restart after reaching the nominal input voltage range

Admissible temperatures

Version	Ambient (t_a)	Case (t_c)
BCS17.1-2Q	- 20 °C ... + 50 °C	max. + 70 °C
BCS18.1-2Q	- 20 °C ... + 60 °C	max. + 75 °C
BCS21.1-2Q	- 20 °C ... + 60 °C	max. + 75 °C
BCS42.1/26.2Q	- 20 °C ... + 60 °C	max. + 75 °C
BCS70.1/42.2Q	- 20 °C ... + 50 °C	max. + 80 °C

Inrush current / Circuit breaker

Version	typ. $I_{peak} / \Delta t$	No. of ECG at single-pole circuit breakers				
		LS-Typ	10 A	16 A	20 A	25 A
BCS17.1-2Q	14 A / 216 μs	B	21	33	42	53
		C	35	56	70	88
BCS18.1-2Q	12 A / 265 μs	B	25	41	51	64
		C	42	68	85	106
BCS21.1-2Q	12 A / 265 μs	B	25	41	51	64
		C	42	68	85	106
BCS42.1/26.2Q	12 A / 265 μs	B	25	41	51	64
		C	35	56	70	88
BCS70.1/42.2Q	33 A / 306 μs	B	7	12	15	19
		C	12	20	25	32

All data for $U_{supply} = 230 VAC$, mains impedance = 1 Ω

In case of multipolar CB the max. no. is reduced by 20 %

The max. number may differ depending on CB manufacturer. Please consider the specifications of the manufacturer.

Basically, CB with C-characteristics are recommended to be used in lighting groups.

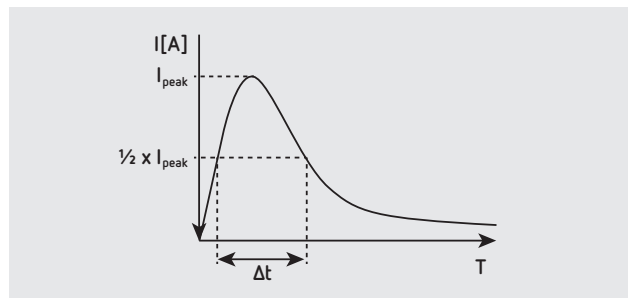

Non-dimmable electronic control gear units
for compact fluorescent lamps in Twingle technology

Operating data

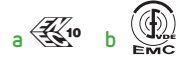

Version	Lamp	System rating		Input current*	Operating frequency	Power factor	Lamp socket	Lamp power	EEL	Approvals
		W	A							
BCS17.1-2Q-01/220-240	1/2 x TC-HE 14 W	17/32	0,08/0,15	50	0,98	GR14q	14	A2	a	
	1/2 x TC-HE 17 W	20/38	0,10/0,17	50	0,98	GR14q	17	A2	a	
BCS18.1-2Q-01/220-240	1/2 x TC-DEL/-TEL 18 W	19/37	0,08/0,17	41	0,95	G24q-2	16	A2	a, b	
BCS21.1-2Q-01/220-240	1/2 x T5 14 W	15/28	0,07/0,13	50	0,90	G5	14	A2	-	
	1 x T5 21 W	22	0,10	50	0,90	G5	21	A2	-	
	1/2 x TC-DD 10 W	12/21	0,05/0,10	50	0,90	GR10q	10	A2	-	
	1/2 x TC-DD 16 W	17/29	0,07/0,14	50	0,90	GR10q	16	A2	-	
	1/2 x TC-DEL 10 W	12/21	0,05/0,10	50	0,90	G24q-1	10	A2	a,b	
	1/2 x TC-DEL/-TEL 13 W	14/27	0,07/0,13	50	0,90	G24q-1/GX24q-1	12	A2	a, b	
	1/2 x TC-SE 9 W	11/20	0,05/0,09	50	0,90	2G7	9	A2	a, b	
	1/2 x TC-SE 11 W	13/25	0,06/0,12	50	0,90	2G7	11	A2	a, b	
BCS42.1/26.2Q-01/220-240	1 x T12 40 W	37	0,17	45	0,95	G13	36	A2	-	
	1/2 x T5C 22 W	24/48	0,11/0,22	45	0,95	2GX13	22	A2	a, b	
	1 x T5C 40 W	42	0,19	45	0,95	2GX13	40	A2	a, b	
	1/2 x T5 24 W	26/52	0,12/0,24	45	0,95	G5	24	A2	-	
	1 x T5 39 W	40	0,17	45	0,95	G5	39	A2	-	
	1/2 x T8 15 W	17/33	0,08/0,15	45	0,95	G13	14	A2	-	
	1/2 x T8 18 W	19/38	0,09/0,16	45	0,95	G13	16	A2	-	
	1 x T8 36 W	36	0,16	45	0,95	G13	32	A2	-	
	1 x T8 38 W	37	0,17	45	0,95	G13	32	A2	-	
	1/2 x TC-DEL/-TEL 26 W	26/52	0,12/0,24	45	0,95	G24q-3/GX24q-3	24	A2	a, b	
	1/2 x TC-L/-F 18 W	18/36	0,08/0,16	45	0,95	2G10/2G11	16	A2	a, b	
	1/2 x TC-L/-F 24 W	24/48	0,11/0,22	45	0,95	2G10/2G11	22	A2	a, b	
	1 x TC-L 40 W	42	0,19	45	0,95	2G11	40	A2	a, b	
	1 x TC-TEL 32 W	35	0,16	45	0,95	GX24q-3	32	A2	a, b	
	1 x TC-TEL 42 W	45	0,21	45	0,95	GX24q-4	42	A2	a, b	
BCS70.1/42.2Q-01/220-240	1/2 x TC-DEL/-TEL 26 W	27/53	0,13/0,24	45	0,95	G24q-3/GX24q-3	24	A2	a	
	1/2 x TC-TEL 32 W	35/71	0,16/0,31	45	0,95	GX24q-3	32	A2	a	
	1/2 x TC-TEL 42 W	47/94	0,21/0,42	45	0,95	GX24q-4	42	A2	a	
	1 x TC-TEL 57 W	61	0,27	45	0,95	GX24q-5	57	A2	a	
	1 x TC-TEL 70 W	75	0,33	45	0,95	GX24q-6	70	A2	a	
	2 x T5C 22 W	49	0,22	45	0,95	2GX13	22	A2	a	
	2 x T5C 40&22 W	68	0,30	45	0,95	2GX13	40&22	A2	a	

* at U_{Mains} = 230 VAC

BCS
TC Twingle
Series

Non-dimmable electronic control gear units for compact fluorescent lamps in Twingle technology

Dimensions

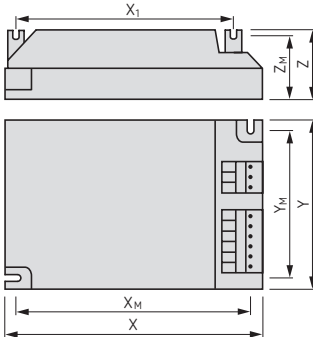

Version	X mm	X _M mm	X ₁ mm	Y mm	Y _M mm	Z mm	Z _M mm	Weight kg
BCS17.1-2Q	103	94	83	67	57	30	28	0,13
BCS18.1-2Q	103	94	83	67	57	30	28	0,13
BCS21.1-2Q	103	94	83	67	57	30	28	0,13
BCS42.1/26.2Q	103	94	83	67	57	30	28	0,14
BCS70.1/42.2Q	103	94	83	67	57	30	28	0,15

Wiring diagrams

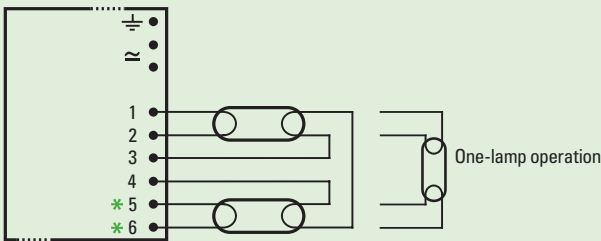

* Please keep lamp wires as short as possible.

Cable capacity:
max. 130 pF between each lamp line
max. 65 pF between each lamp line.
Please ensure that the wiring layout is symmetrical.

Conformance with regulations

EN 61 347-1	General and safety requirements
EN 61 347-2-3	
EN 61 347-2-3/C	Requirements for thermally protected ballasts
EN 61347-2-3/J	Particular additional safety requirements for a.c./d.c. supplied electronic ballasts for emergency lighting
EN 60 929	Performance requirements
EN 50 294	Measurement method of total input power of ballast-lamp circuits
EN 61 000-3-2	Limits for harmonic current emissions
EN 61 000-3-3	Limitation of voltage fluctuations and flicker
General EMC immunity:	
EN 61 000-4-2	Electrostatic discharge
EN 61 000-4-3	Radiated, radio-frequency, electromagnetic field
EN 61 000-4-4	Electrical fast transient /burst
EN 61 000-4-5	Surge
EN 61 000-4-6	Conducted disturbances, induced by radio-frequency fields
EN 61 000-4-8	Power frequency magnetic field
EN 61 000-4-11	Voltage dips, short interruptions and voltage variations
EN 61 547	EMC immunity: equipment for general lighting purposes
EN 55 015	Radio disturbances, frequencies < 300MHz (CDN method)
Environmental tests for mechanical capacity:	
IEC 60 068-2-6	Test Fc: vibrations (sinusoidal)
IEC 60 068-2-27	Test Ea: shock and bump
IEC 60 068-2-29	Test Eb: shock and bump
Quality management certified according to ISO 9001	